

**Basin single-lever mixer
with pop-up waste
3.1120.1.004.111.1
without pop-up waste
3.1120.1.004.110.1**



TECHNICAL DATA / WITH POP-UP WASTE

Order no.	3.1120.1.004.111.1
Connection	3/8" flexible connection hoses
Spout length	106 mm
Flow rate	5.7 l/min (3 bar)
Acoustic class	I/-
Specification	basin single-lever mixer Eco+ function, cold water handle in the middle cartridge C35 fixed spout
Accessories incl.	pop-up waste 1¼"
Surface finish	chrome

TECHNICAL DATA / WITHOUT POP-UP WASTE

Order no.	3.1120.1.004.110.1
Connection	3/8" flexible connection hoses
Spout length	106 mm
Flow rate	5.7 l/min (3 bar)
Acoustic class	I/-
Specification	basin single-lever mixer Eco+ function, cold water handle in the middle cartridge C35 fixed spout
Surface finish	chrome

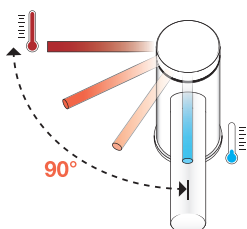

TECHNICAL DRAWINGS

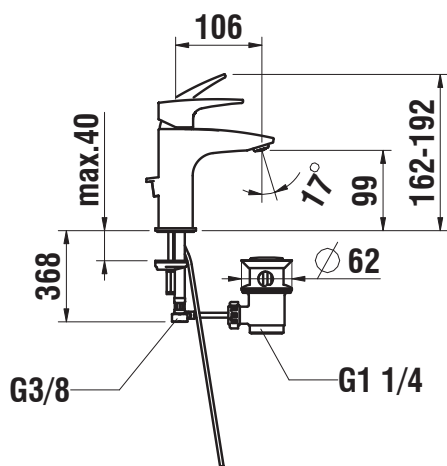

TECHNICAL DRAWINGS

